

机械式轴封 Mechanical Shaft Seal

TSJ(24)26×12.7R

TS C-505动

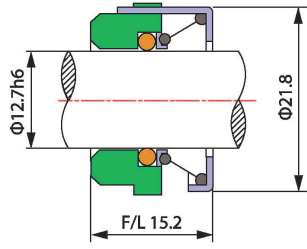

For Sanden(三电) SD505 / 575 / 507mini, Sanden(三电) SDTR70 / 90 / 105 Compressor

TSJ26×12.7ST

TS C-505静

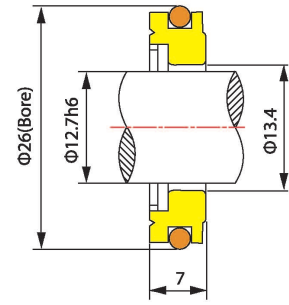

TSJ24×12.7ST

TS C-505B静

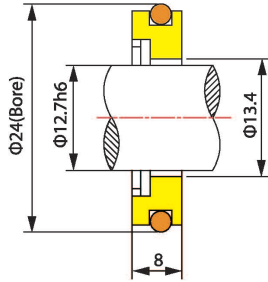

For Mitsubishi(三菱) NL / SA, Panasonic(松下) Compressor

TSJ26×14.3ST

TS C-709A静

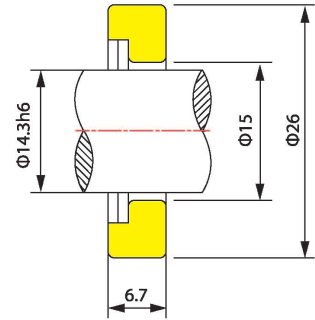

TSJ28×14.3AR

TS C-708动

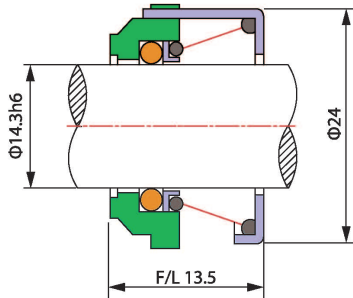

For Sanden(三电) SD708 / 709

TSJ28×14.3ABST

TS C-708静 TS C-709静

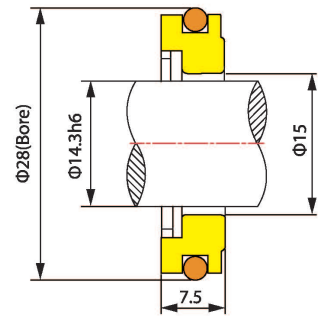

TSJ28×14.3BR

TS C-709动

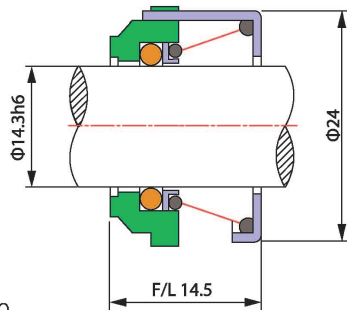

For Sanden(三电) SD708 / 709

技术参数:

压力: ≤0.3MPa
 转速: ≤6000转/分
 温度: -30°C ~ +150°C

Operating Limits

Pressure: ≤0.3MPa
 Rotary Speed: ≤6000 r/min
 Temperature: -30°C ~ +150°C

- 动环(热压石墨)
- 静环(铸铁/不锈钢/陶瓷)
- 橡胶件(丁腈胶/ 氢化丁腈胶)
- 弹簧(锰钢/不锈钢)
- 冲压件(A3铁/不锈钢)

- Rotary Ring(Plastic Carbon)
- Stationary Ring(Cast Iron/SUS304/Ceramic)
- Rubber Parts(NBR/HNBR)
- Spring(65Mn/SUS304/SUS316)
- Punching Parts(A3/SUS304)

机械式轴封 Mechanical Shaft Seal

TRISUN 派

TSJ30×14.3AR

TS C-6P动

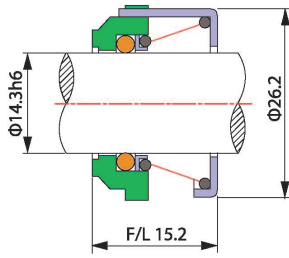

TSJ30×14.3AST

TS C-6P静

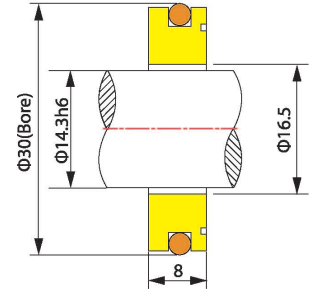

For Chrysler(克莱斯勒) C171 / A590, Ford(福特) FS6, Nippon Denso(日本电装) 10P13 / 10P15 / 10P08e / P127 / 134 / 148 / 6E171

TSJ30×14.3ABR

TS C-6PA动

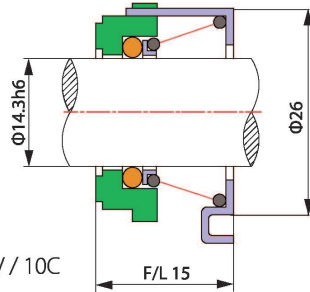

For Nippon Denso(日本电装) TV / 10C

TSJ30×14.3BST

TS C-6PA静

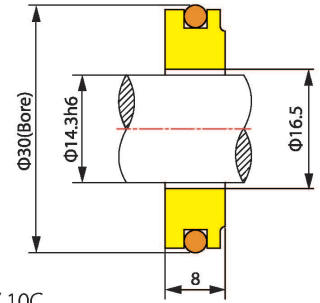

For Nippon Denso(日本电装) TV / 10C

TSJ30×14.3CR

TS C-10P动

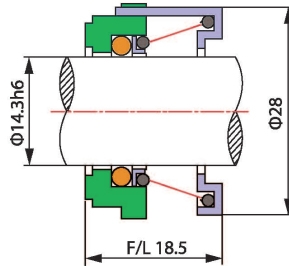

For Ford(福特) FS6 / 6P / 6E / 10P, Nippon Denso(日本电装) 10P17 / 10P08E / 10P13 / 10P15 / 10PA 17 / 6P127A / 6P127B / 6P134 / 6P148

TSJ30×14.3CST

TS C-10P静

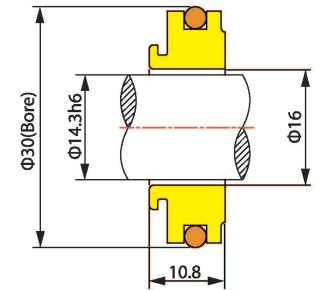

For Nippon Denso(日本电装) 10P17 / 10P08E / 10P13, Ford(福特) FS6 / 6E / 6P / 10P Compressor

TSJ30×14.3DR

TS C-6PB动

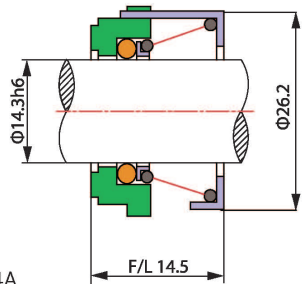

For ZEXEL(杰克赛尔) DKS14C,14A

TSJ30×14.3EST

TS C-508B静

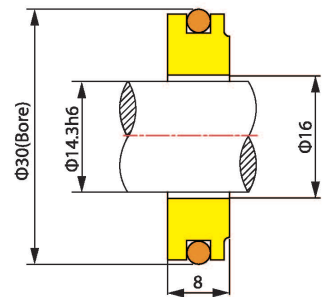

技术参数:

压力: $\leq 0.3\text{MPa}$
 转速: $\leq 6000\text{转/分}$
 温度: $-30^{\circ}\text{C} \sim +150^{\circ}\text{C}$

- 动环(热压石墨)
- 静环(铸铁/不锈钢/陶瓷)
- 橡胶件(丁腈胶/ 氢化丁腈胶)
- 弹簧(锰钢/不锈钢)
- 冲压件(A3铁/不锈钢)

Operating Limits

Pressure: $\leq 0.3\text{MPa}$
 Rotary Speed: $\leq 6000\text{ r/min}$
 Temperature: $-30^{\circ}\text{C} \sim +150^{\circ}\text{C}$

- Rotary Ring(Plastic Carbon)
- Stationary Ring(Cast Iron/SUS304/Ceramic)
- Rubber Parts(NBR/HNBR)
- Spring(65Mn/SUS304/SUS316)
- Punching Parts(A3/SUS304)

机械式轴封 Mechanical Shaft Seal

TSJ30.1×14.3R
TS C-508动

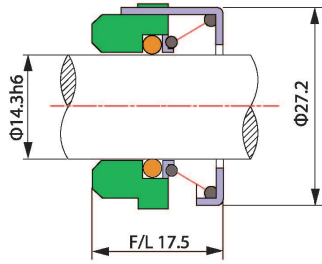

TSJ30.1×14.3ST
TS C-508静

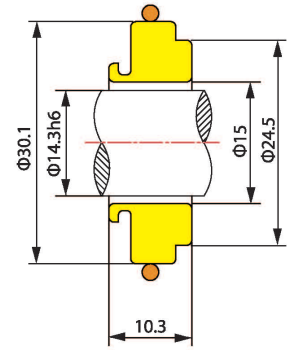

For Sanden(三电) SD507 / 508, Ford(福特) HR980, GM(通用) A6 / R4, RD507 / 508 / 510, York (约克) YA12 / 15, Seiko Seiki(日本精工精机) SS148PB / 170PSS / 811PB5

TSJ31.5×14.3ST
TS C-508C静

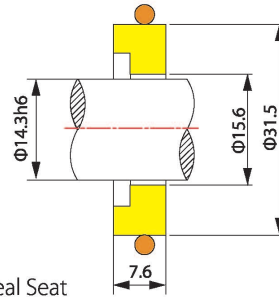

For GM(通用) A6 / R4, Ford(福特) HR980 Ceramic Seal Seat

TSJ30×16R
TS C-10PA动

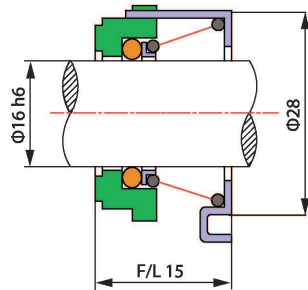

For Nippon Denso(日本电装) TV12C / 14C, TV12EC / TV12SC

TSJ30×16ST
TS C-10PA静

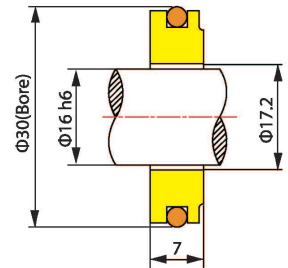

For Nippon Denso(日本电装) TV12C / 14C / TV12EC / TC12SC Steel Seat

TSJ35×16R
TS C-10P30动

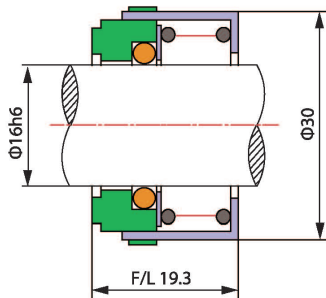

For Nippon Denso(日本电装) 10PA25C / 10PA20C

TSJ35×16ST
TS C-10P30静

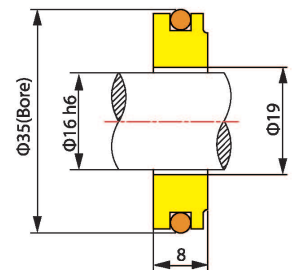

For Nippon Denso(日本电装) 10PA25C / 10PA20C Steel Seat

- 动环(热压石墨)
- 静环(铸铁/不锈钢/陶瓷)
- 橡胶件(丁腈胶/ 氯化丁腈胶)
- 弹簧(锰钢/不锈钢)
- 冲压件(A3铁/不锈钢)

- Rotary Ring(Plastic Carbon)
- Stationary Ring(Cast Iron/SUS304/Ceramic)
- Rubber Parts(NBR/HNBR)
- Spring(65Mn/SUS304/SUS316)
- Punching Parts(A3/SUS304)

机械式轴封 Mechanical Shaft Seal

TRISUN 天

www.trisunltd.com
ISO9001 & TS16949

TSJ40×20R
TS C-10P20动

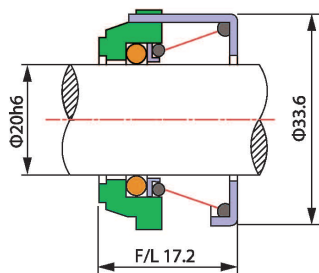

TSJ40×20ST
TS C-10P20静

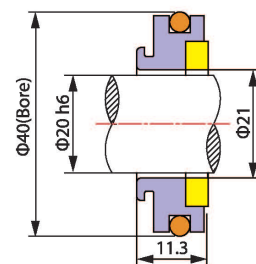

TSJ40×24R
TS C-10P24动

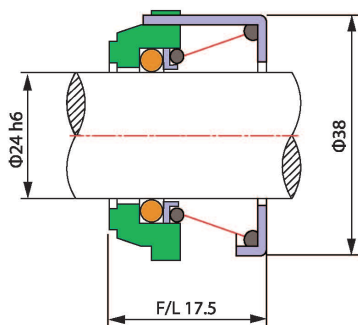

TSJ40×24ST
TS C-10P24静

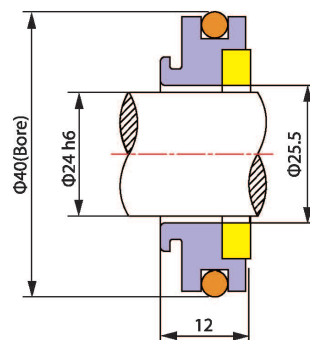

TSJ45×25R
TS C-25动

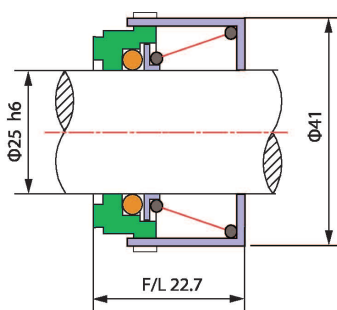

TSJ45×25ST
TS C-25静

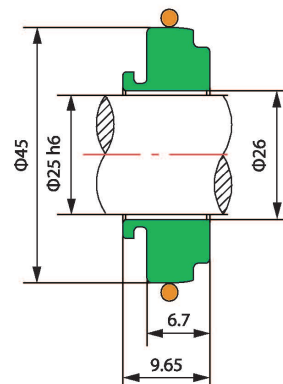

技术参数:

压力: $\leq 0.3\text{MPa}$
转速: $\leq 6000\text{转/分}$
温度: $-30^{\circ}\text{C} \sim +150^{\circ}\text{C}$

Operating Limits

Pressure: $\leq 0.3\text{MPa}$
Rotary Speed: $\leq 6000\text{ r/min}$
Temperature: $-30^{\circ}\text{C} \sim +150^{\circ}\text{C}$

- 动环(车制石墨)
- 静环(碳化硅/不锈钢)
- 橡胶件(丁腈胶/ 氢化丁腈胶)
- 弹簧(锰钢/不锈钢)
- 其他配件(A3铁/不锈钢)
- Rotary Ring(Carbon)
- Stationary Ring(SiC/SUS 304)
- Rubber Parts(NBR/HNBR)
- Spring(65Mn/SUS304/SUS316)
- Other Parts(A3/SUS304)

防尘罩 Felt Wiper Ring With Retainer



TSJ26×12.7F
TS C-505 F

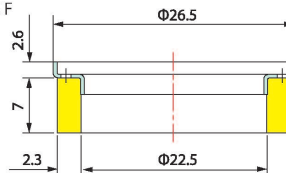

For Sanden(三电) SD505 / 507 Felt Wiper Ring With Retainer

TSJ30.1×14.3F
TS C-508 F

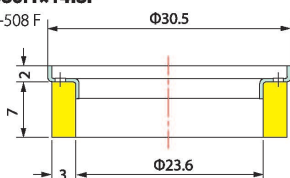

For Sanden(三电) SD507 / 508 / 510 Felt Wiper Ring With Retainer
空调压缩机用密封件 | Air-Condition Compressor Seal

TS CT26×14.3F
TS CT-508 F

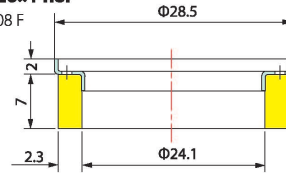

For Sanden(三电) SD708 / 709 Felt Wiper Ring With Retainer

机械式轴封 Mechanical Shaft Seal

TSJH14.3R

TS CH-905

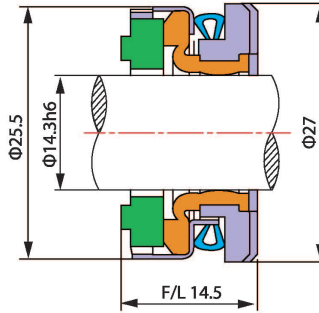

For Chrysler(克莱斯勒) C171 / A590,
Ford(福特) FS6, Nippon Denso
(日本电装) 6P / 6E / 10P / 10PA /
10P08E, SS170

TSJH20R

TS CH-20

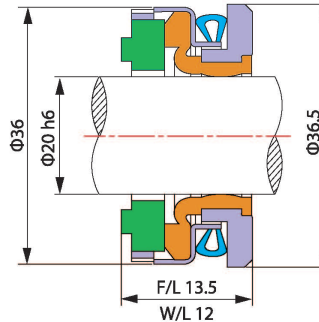

For Chrysler(克莱斯勒) RV12
Carbon Seal Compressor

TSJH74.4x22R

TS CH-26动

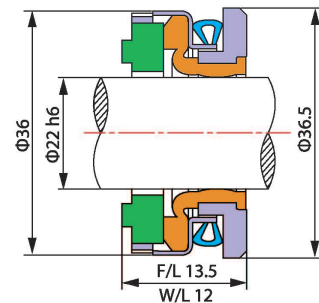

For York(约克) 6 Bolt(7/32")
Compressor York 206,209,
210,SC206,SC209,Tecumseh
HG500

TSJH74.4x22ST

TS CH-26静

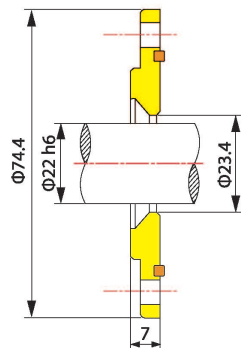

For York(约克) 6 Bolt(7 / 32"holes)
Compressor Seat Plate York206,
209,210,SC206,SC209,Tecumseh
HG500

技术参数:

压力: $\leq 0.3\text{MPa}$
转速: ≤ 6000 转/分
温度: $-30^{\circ}\text{C} \sim +150^{\circ}\text{C}$

Operating Limits

Pressure: $\leq 0.3\text{MPa}$
Rotary Speed: ≤ 6000 r/min
Temperature: $-30^{\circ}\text{C} \sim +150^{\circ}\text{C}$

- 动环(石墨)
- 静环(铬钢/不锈钢)
- 橡胶件(氢化丁腈胶)
- 波簧(17-7PH/锰钢)
- 其它配件(A3铁/不锈钢)

- Rotary Ring(Carbon)
- Stationary Ring(2Cr13/SUS304)
- Rubber Parts(HNBR)
- Wave Spring(17-7PH/65Mn)
- Other Parts(A3/SUS304)

机械式轴封 Mechanical Shaft Seal

TRISUN 瓦

www.trisunltd.com
ISO9001 & TS16949

TSJH60×40
TS C-40 (德国进口)

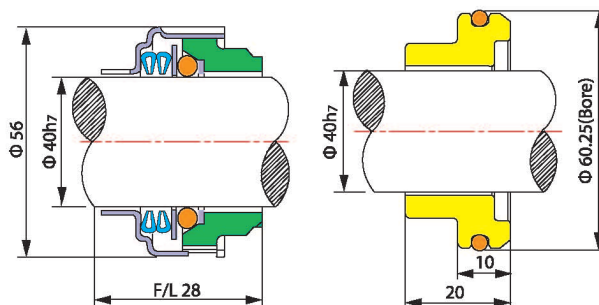

TSJH60×40B
TS C-40B

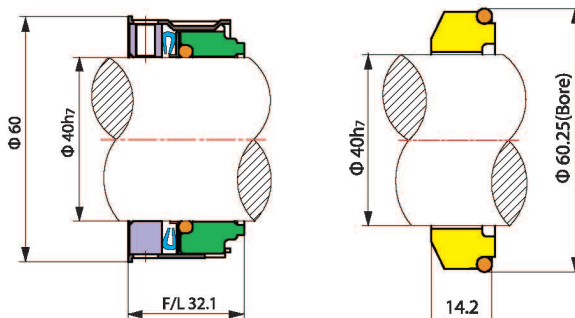

TSJH60×40C
TS C-40C(比兹尔新款)

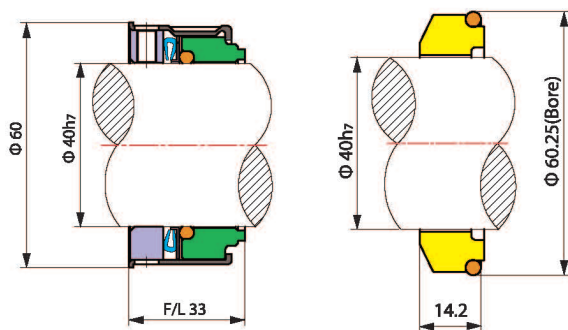

技术参数:

压力: ≤1.2MPa
线速度: ≤10米/秒
温度: -30°C ~ +150°C

Operating Limits

Pressure: ≤1.2MPa
Speed: ≤10m/s
Temperature: -30°C ~ +150°C

- 动环(填充石墨的PTFE/车制石墨)
- 静环(碳化硅/进口铬钢)
- 橡胶件(氢化丁腈胶)
- 波簧(17-7 PH/不锈钢)
- 其它配件(不锈钢/铝)
- Rotary Ring(PTFE Filled Carbon/Carbon)
- Stationary Ring(SiC/Imported Steel)
- Rubber Parts(HNBR)
- Wave Spring(17-7 PH/SUS316)
- Other Parts(SUS304/SUS316/Aluminium)

TSJA

TS CA



- 动环(车制石墨)
- 静环(铬钢/碳化硅)
- 橡胶件(氢化丁腈胶)
- 冲压件(A3铁/不锈钢)
- 波簧(17-7 PH/不锈钢)
- 销钉(不锈钢)
- Rotary Ring(Carbon)
- Stationary Ring(9Cr18/SiC)
- Rubber Parts(HNBR)
- Punching Parts(A3/SUS304/SUS316)
- Wave Spring(17-7 PH/SUS316)
- Pin(SUS304/SUS316)

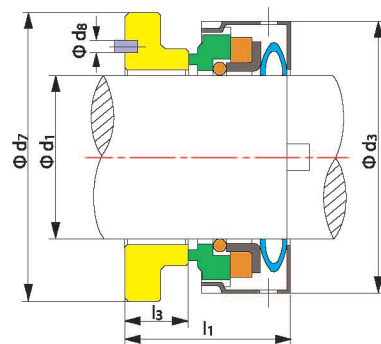

Model	d ₁ (mm)	d ₃	d ₇	d ₈	l ₁	l ₃
TSJA-40	40	62	68	3	32.5	15
TSJA-50	50	74	\	\	29.5	13
TSJA-60	60	84	95	3	29.5	13
TSJA-65	65	89	98	3	30.5	14

机械式轴封 Mechanical Shaft Seal

TSJK60×40

TS CK-40B



For Bock(博克) FK40 Series Compressors (Domestic)

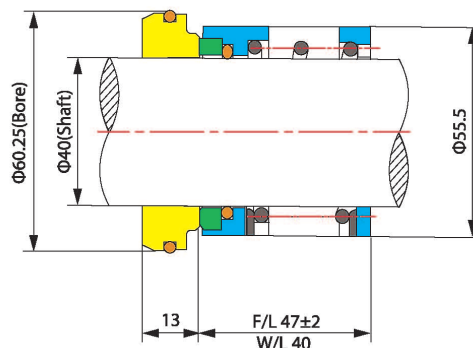

TSJK90×40A

TS CK-40



For Bock(博克) FK40 Series Vehicle Compressors

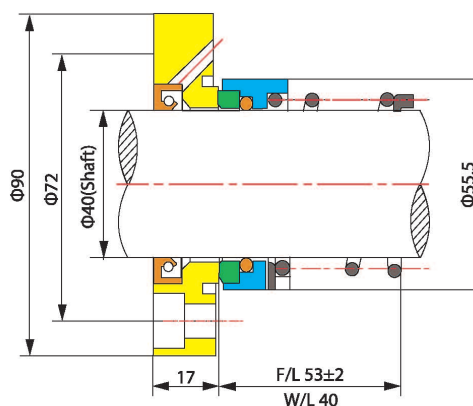

TSJK90×40B

TS CK-40A



For Bock (博克) FK40 Series Vehicle Compressors (Domestic)

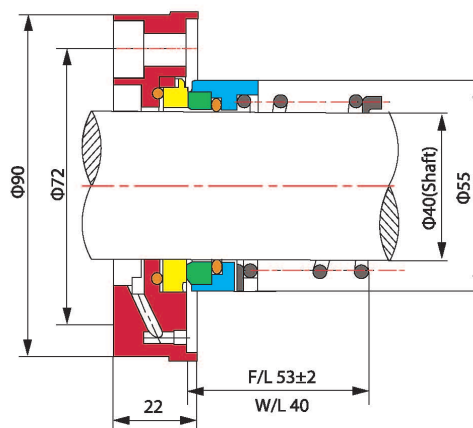

技术参数:

压力: $\leq 1.2\text{MPa}$
 转速: $\leq 4000\text{转/分}$
 温度: $-30^{\circ}\text{C} \sim +150^{\circ}\text{C}$

- 动环(车制石墨/填充石墨的PTFE)
- 静环(铸铁/碳化硅)
- 辅助密封(氢化丁腈胶)
- 弹簧(锰钢)
- 传动套(铸铝)
- 其它配件(铬钢)

Operating Limits

Pressure: $\leq 1.2\text{MPa}$
 Rotary Speed: $\leq 4000\text{r/min}$
 Temperature: $-30^{\circ}\text{C} \sim +150^{\circ}\text{C}$

- Rotary Ring (Carbon/PTFE Filled Carbon)
- Stationary Ring (Cast Iron/SiC)
- Secondary Seal (HNBR)
- Spring (65Mn)
- Retainer (Molten Aluminium)
- Other Parts (Steel)

金属波纹管轴封 Metal Bellows Seal

TSJ607 TS 607

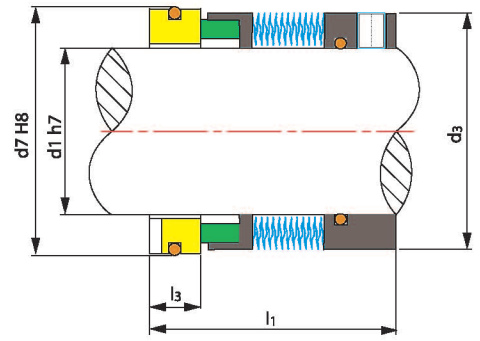

技术参数:

压力: $\leq 2\text{MPa}$
线速度: $\leq 20\text{米/秒}$
温度: $-30^{\circ}\text{C} \sim +250^{\circ}\text{C}$

- 动环(车制石墨/碳化硅)
- 静环(碳化硅/碳化钨)
- 辅助密封(氢化丁腈胶/氟胶)
- 金属波纹管(AM350/SUS316L)
- 其它车制件(不锈钢)

Operating Limits

Pressure: $\leq 2\text{MPa}$
Speed: $\leq 20\text{m/s}$
Temperature: $-30^{\circ}\text{C} \sim +250^{\circ}\text{C}$

- Rotary Ring (Carbon/SiC)
- Stationary Ring (SiC/TC)
- Secondary Seal (HNBR/VITON)
- Metal Bellows (AM350/SUS316L)
- Other Parts (SUS316)

适用于大型空调压缩机 For Big Air-Condition Compressor

Model	d ₁	d ₃	d ₇	l ₁	l ₃
TSJ607-18	18	32.0	33	40.8	10.0
TSJ607-20	20	34.0	35	40.8	10.0
TSJ607-22	22	36.0	37	40.8	10.0
TSJ607-24	24	38.0	39	41.4	10.0
TSJ607-25	25	39.0	40	41.4	10.0
TSJ607-28	28	42.0	43	41.7	10.0
TSJ607-30	30	44.0	45	43.1	10.0
TSJ607-32	32	46.0	48	43.1	10.0
TSJ607-33	33	47.0	48	45.4	10.0
TSJ607-35	35	49.2	50	46.4	10.0
TSJ607-38	38	54.0	56	47.4	11.0
TSJ607-40	40	56.0	58	47.4	11.0
TSJ607-43	43	59.0	61	47.7	11.0
TSJ607-45	45	61.0	63	47.7	11.0
TSJ607-48	48	64.0	66	48.1	11.0
TSJ607-50	50	66.0	70	50.1	13.0
TSJ607-53	53	69.0	73	50.2	13.0
TSJ607-55	55	71.0	75	51.7	13.0
TSJ607-60	60	80.0	80	53.7	13.0
TSJ607-65	65	85.0	85	55.4	13.0
TSJ607-70	70	90.0	92	58.7	15.3
TSJ607-75	75	99.0	97	60.9	15.3
TSJ607-80	80	104.0	105	62.9	15.7
TSJ607-85	85	109.0	110	62.9	15.7
TSJ607-90	90	114.0	115	64.4	15.7
TSJ607-95	95	119.0	120	64.4	15.7
TSJ607-100	100	124.0	125	64.4	15.7

金属波纹管轴封 Metal Bellows Seal



TS Carrier



TS Carrier-30



TS Bitzer



TS Carrier-1"

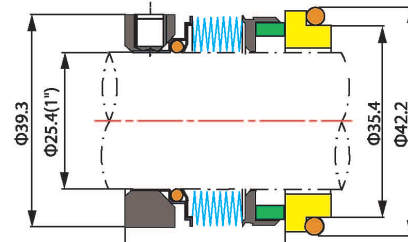
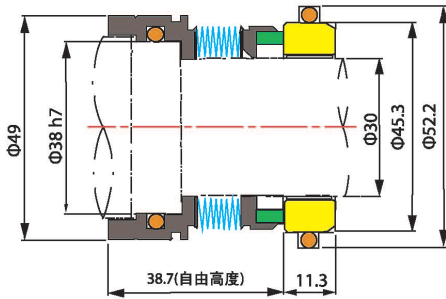

用于开利大巴 For Carrier Compressor

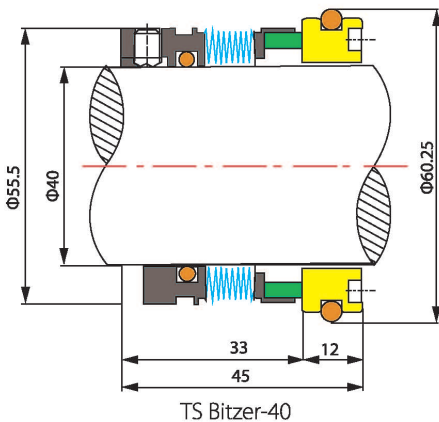

TS Bitzer-40

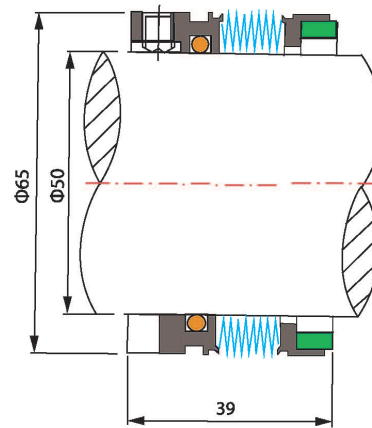

TS Bitzer-50

用于比兹尔大巴 For Bitzer Compressor

技术参数:

压力: $\leq 2\text{MPa}$
 线速度: $\leq 20\text{米/秒}$
 温度: $-30^{\circ}\text{C} \sim +250^{\circ}\text{C}$

Operating Limits

Pressure: $\leq 2\text{MPa}$
 Speed: $\leq 20\text{m/s}$
 Temperature: $-30^{\circ}\text{C} \sim +250^{\circ}\text{C}$

- 动环(车制石墨/碳化硅)
- 静环(碳化硅/碳化钨)
- 辅助密封(氢化丁腈胶/氟胶)
- 金属波纹管(AM350/SUS316L)
- 其他车制件(不锈钢)

- Rotary Ring (Carbon/SiC)
- Stationary Ring (SiC/TC)
- Secondary Seal (HNBR/VITON)
- Metal Bellows (AM350/SUS316L)
- Other Parts (SUS316)

机械式轴封 Mechanical Shaft Seal



TSJ 580



with PTFE



TSJ 580B-2"A

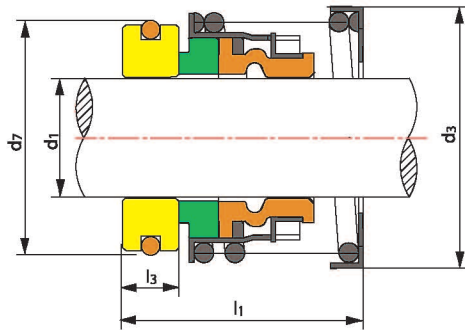

TSJ580

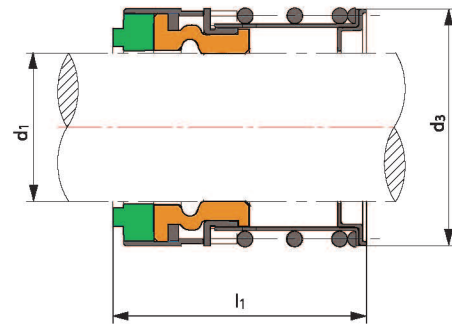

TSJ580B-2"A

用于开利大巴 For Carrier Compressor

技术参数:

压力: $\leq 2.8\text{MPa}$
线速度: $\leq 13\text{米/秒}$
温度: $-30^\circ\text{C} \sim +150^\circ\text{C}$

Operating Limits

Pressure: $\leq 2.8\text{MPa}$
Speed: $\leq 13\text{m/s}$
Temperature: $-30^\circ\text{C} \sim +150^\circ\text{C}$

- 动环(车制石墨/碳化硅)
- 静环(碳化硅/铸铁)
- 辅助密封(氢化丁腈胶)
- 弹簧及冲件(不锈钢/A3铁)

- Rotary Ring (Carbon/SiC)
- Stationary Ring (SiC/Cast Iron)
- Secondary Seal (HNBR)
- Spring & Other Parts (SUS304/SUS316/A3)

Model	d ₁ (inches)	d ₃	d ₇	l ₁	l ₃	F.H
TSJ580-1 1/4"	31.750	59.0	50.800	44.9	11.9	\
TSJ580-1 3/8"	34.925	63.0	54.000	44.9	11.9	\
TSJ580-1 1/2"	38.100	67.0	57.150	44.9	11.9	\
TSJ580-1 5/8"	41.275	71.0	60.350	44.9	11.9	\
TSJ580-1 3/4"	44.450	74.0	63.500	52.9	11.9	\
TSJ580-1 7/8"	47.625	77.0	66.700	52.9	11.9	\
TSJ580-7/8"C	22.225	41.2	38.100	35.7	10.3	39.5
TSJ580-1"B	25.400	46.0	41.275	39.7	11.1	\
TSJ580-1"D	25.400	46.4	38.100	31.8	5.80	36.0
TSJ580-13/8"A	34.925	55.8	50.800	41.3	13.0	63.0
TSJ580-17/16"A	36.500	55.5	52.500	50.0	11.1	68.0
TSJ580-11/2"C	38.100	60.6	53.975	54.3	11.3	57.5
TSJ580-11/2"D(with PTFE)	38.100	60.5	53.975	54.3	11.3	57.5
TSJ580-2"B	50.800	80.8	\	35.0	\	38.0
TSJ580B-2"A	50.800	65.5	\	55.0	\	58.0

唇形轴封 Lip Type Shaft Seals

TSCT23×12.7

TS CT-505H

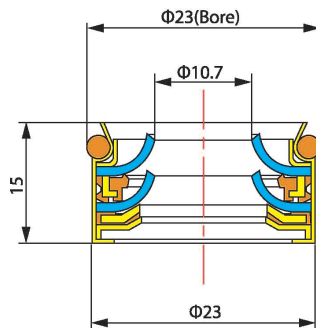

For Panasonic(松下) Lip Seal
Ford Telstar 94`95`

TSCT 24×12.7

TS CT-505

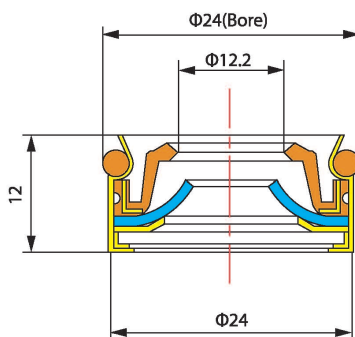

For Sanden(三电) SD505 / 507,
TR70 / TR105, Mitsubishi(三菱)
MSC90C / MSC105 / FX80 / FX105V,
SH942 / K600, Honda(本田) K600

TSCT 26×14.3

TS CT-508

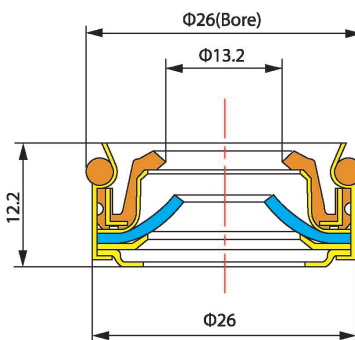

For Sanden(三电) SD7V16 / 5H14,
709 / 7HB / 7H15 / 7B10, TAMA1020,
Seiki Seiko(日本精工精机) SS96,
Nippon Denso(日本电装) ND7SB

TSCT 30×14.3

TS CT-10P17B

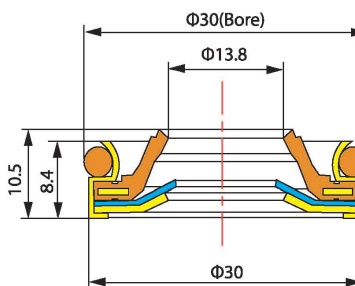

For Denso(电装) TV12 / TV14

技术参数:

压力: ≤0.3MPa
转速: ≤6000转/分
温度: -30℃~+150℃

- 金属件(A3铁/不锈钢)
- 橡胶件(氢化丁腈胶)
- 密封圈(聚四氟乙烯)

Operating Limits

Pressure: ≤0.3MPa
Rotary Speed: ≤6000r/min
Temperature: -30℃~+150℃

- Metal Parts(A3/SUS304)
- Rubber Parts(HNBR)
- Seal Ring(PTFE)

唇形轴封 Lip Type Shaft Seals

TRISUN 冠

TSCTF26×14.3

TS CT-709

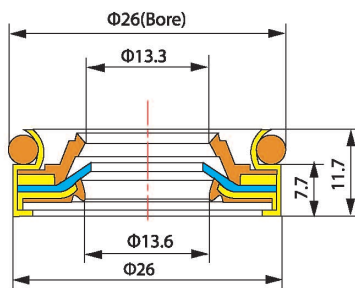

For Sanden(三电) SD708 / 709

TSCTF30×14.3A

TS CT-30A

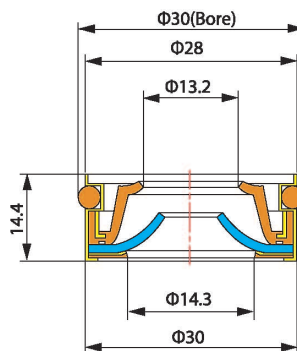

For ZEXEL(杰克赛尔) DKS11D / 14D / 16H

TSCTF30×14.3B

TS CT-10P17

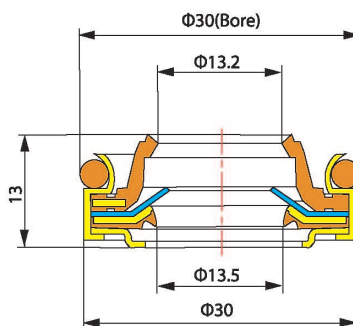

For Nippon Denso
(日本电装) 10P08E, Chrysler
(克莱斯勒) 6C / 6CA17 / 6P17C

TSCTF30×14.3C

TS CT-10P17A

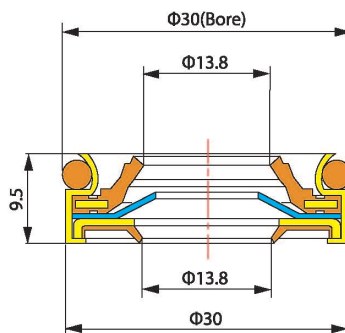

For Nippon Denso
(日本电装) TV12 / 14
Calsonic(日本康奈可)
Nissan Cefiro(尼桑) A30 / A32

技术参数:

压力: $\leq 0.3\text{MPa}$
转速: $\leq 6000\text{转/分}$
温度: $-30^{\circ}\text{C} \sim +150^{\circ}\text{C}$

- 金属件(A3铁/不锈钢)
- 橡胶件(氢化丁腈胶)
- 密封圈(聚四氟乙烯)

Operating Limits

Pressure: $\leq 0.3\text{MPa}$
Rotary Speed: $\leq 6000\text{r/min}$
Temperature: $-30^{\circ}\text{C} \sim +150^{\circ}\text{C}$

- Metal Parts(A3/SUS304)
- Rubber Parts(HNBR)
- Seal Ring(PTFE)

唇形轴封 Lip Type Shaft Seals

TSCTF30×14.3D

TS CT-10P17M

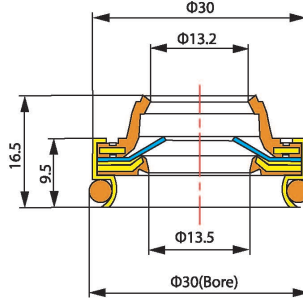

For Nippon Denso(日本电装)
10PA17C / 10PA20C, 10PA15C / 10PA
ZEXEL(杰克赛尔) DKSCV11A
Denso (日本电装) 10PA15 / 10PA17

TSCTF30×16A

TS CT-30

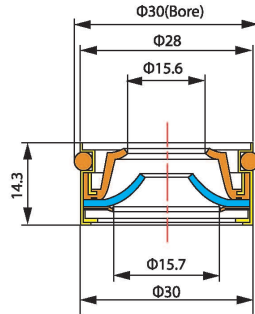

For Diesel Kiki ZEXEL(杰克赛尔) DKS16H

TSCTF30×16B

TS CT-30B

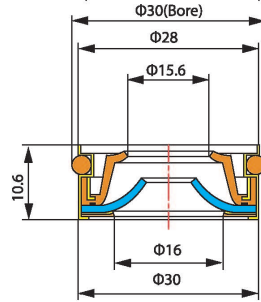

For Seiko Seiki(日本精工精机) SS170
ZEXEL(杰克赛尔) DKS16H, SD709, R12

TSCTF32×17

TS CT-32

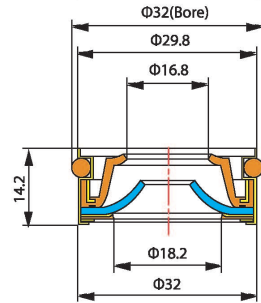

For Tama(凯马) TM131
Diesel Hiki TM31DKS32C

TSCTF35×17

TS CT-10P30C

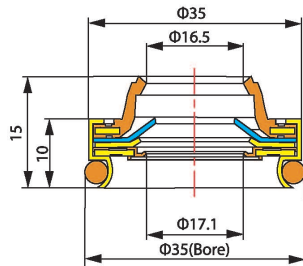

For Nippon Denso(日本电装)
10S30B / 10S30C / 10S20B / 10S20C,
ZEXEL(杰克赛尔) DKS 30C OE#BEL 100-17E

TSCTF40×20

TS CT-40

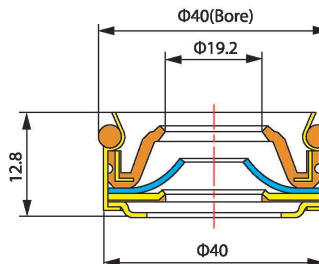

For Toyota(丰田)
Automobile R134A

唇形轴封 Lip Type Shaft Seals

TRISUN 冠

TSCY31.5×14.3B

TS CY-8B

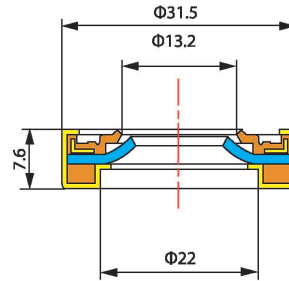

For GM(通用)
DA6 / HT6 / HR6 / HR6HE / R4 / V5

www.trisunltd.com
ISO9001 & TS16949

TSCY31.5×14.3C

TS CY-8C

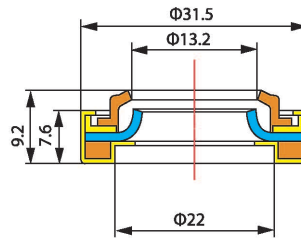

For GM(通用) DA6 / HR6 / V5 / R4

TSCY31.5×14.3D

TS CY-8D

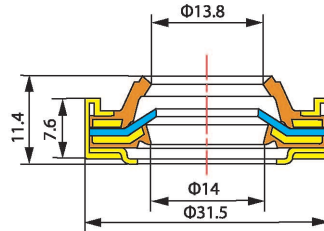
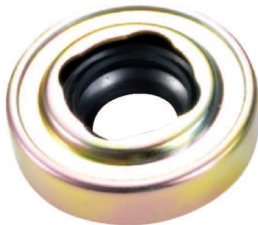

For Audi(奥迪),
Golden Dragon(厦门金龙)
V5 DA6 / HR6 / HT6

TSCY31.5×16

TS CY-8L

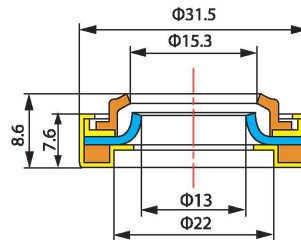

For GM(通用)
Truck HT6 / HU6 Large Shaft,
HRD V7 R134A

技术参数:

压力: $\leq 0.3\text{MPa}$
转速: $\leq 6000\text{转/分}$
温度: $-30^{\circ}\text{C} \sim +150^{\circ}\text{C}$

- 金属件(A3铁/不锈钢)
- 橡胶件(氢化丁腈胶)
- 密封圈(聚四氟乙烯)

Operating Limits

Pressure: $\leq 0.3\text{MPa}$
Rotary Speed: $\leq 6000\text{r/min}$
Temperature: $-30^{\circ}\text{C} \sim +150^{\circ}\text{C}$

- Metal Parts(A3/SUS304)
- Rubber Parts(HNBR)
- Seal Ring(PTFE)

唇形包胶式轴封 Lip Shaft Seals with Rubber-mounted

TSCB24×12.7

TS CB-505A

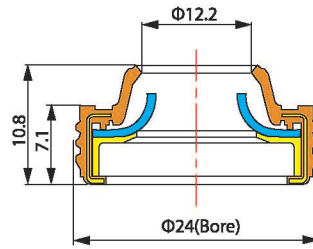

For Mitsubishi(三菱) MSC90C / MSC105C
New Panasonic(松下)
Ford SCROLL

TSCB24×12.7A

TS CB-505D

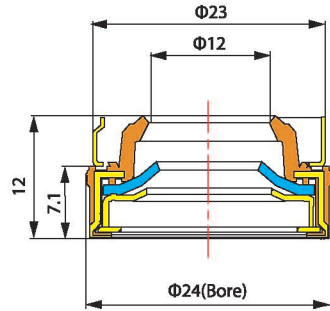

For Mitsubishi(三菱) MSC90C,
MSC105C, New Panasonic(松下)

TSCB26×14.3EA

TS CB-508EA

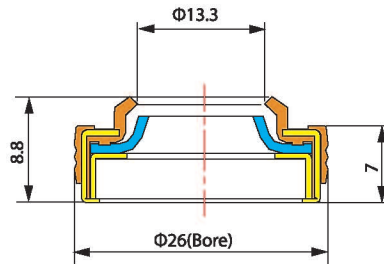

For GM(通用) V5(new)

TSCB23×13.5

TS CB-507

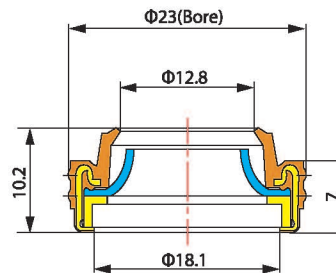

For Ford(福特) FS10 / FX15 / VF2
Visteon HS15, HS17, HS18

TSCB26×14.3A

TS CB-508S

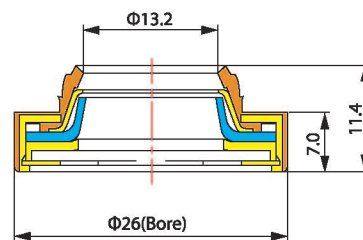

For Daewoo(大宇) V5,
GM(通用) V5 / V7
Tama, Tm08HD, Delphi
cvc-165, cvc-185
Diesel kiki Dcw 17B
DCW17D, Sande PXE16
5H09, 5H11, 5H13, 7H15
7V16. Seiko-Seiki SS10LV6
SS10V1, SS10V6 SS96D1, SS96D2

唇形包胶式轴封 Lip Shaft Seals with Rubber-mounted

TRISUN 冠

www.trisunltd.com
ISO9001 & TS16949

TSCB26×14.3B

TS CB-508H

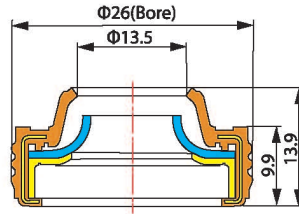

For Volkswagen(大众), Volvo, Audi, Sanden (三电)

TSCB26×14.3C

TS CB-508E

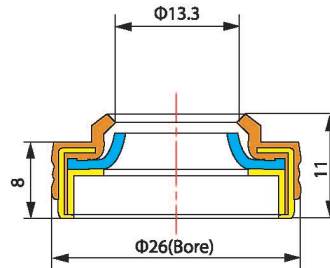

For ZEXEL(杰克赛尔) DKS-17V5 / V7, GM V5 / V7, Mitsubishi(三菱) NSO MSC90 / 105, Calsonic(日本康奈可) V7

TSCB26×14.3D

TS CB-907

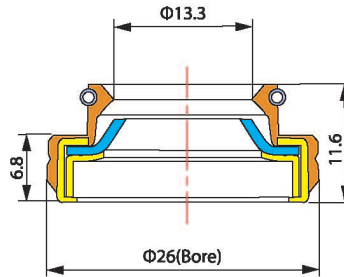

For China Jianshe (中国建设) Compressor

TSCB27×14.3

TS CB-508F

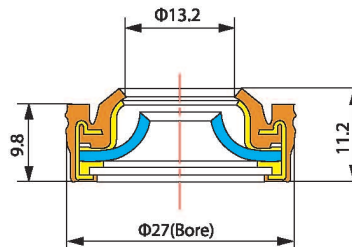

For Sanden(三电) SD7SB, Passat(帕萨特), Benz(奔驰), BMW(宝马), ND 7SB16C

TSCBF28×14.3

TS CB-508C

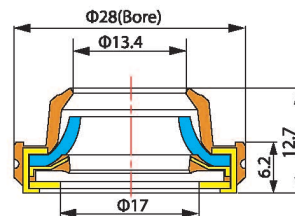

For Hitachi(日立) MJS170

技术参数:

压力: ≤0.3MPa
转速: ≤6000转/分
温度: -30°C ~ +150°C

- 金属件(A3铁/不锈钢)
- 橡胶件(氢化丁腈胶)
- 密封圈(聚四氟乙烯)

Operating Limits

Pressure: ≤0.3MPa
Rotary Speed: ≤6000r/min
Temperature: -30°C ~ +150°C

- Metal Parts(A3/SUS304)
- Rubber Parts(HNBR)
- Seal Ring(PTFE)

唇形包胶式轴封 Lip Shaft Seals with Rubber-mounted

TSCB30×14.3A

TS CB-508A

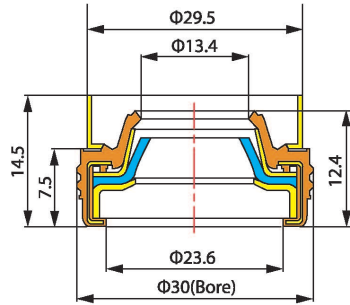

For Tama(凯马) TM08 / 16 /,
New Design SD 507 / 508
DKV 14D / NVR-140S
Nissan CEFIRO

TSCB30×14.3B

TS CB-508B

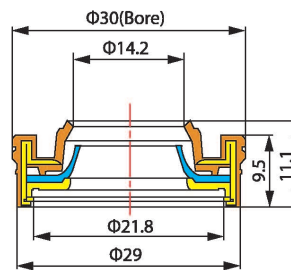

For Nippon Denso
(日本电装) 7SBU16 / 10P17C

TSCB30×14.3C

TS CB-508M

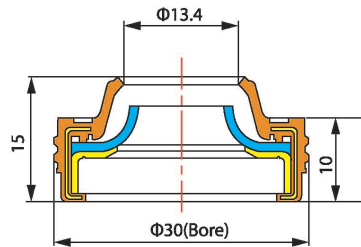

For ZEXEL(杰克赛尔) DKSCA11A,
Nippon Denso(日本电装) 10PA20C,
10PA17C, Panasonic(松下) 15 / 17 / 20

TSCB32×18

TS CB-508L

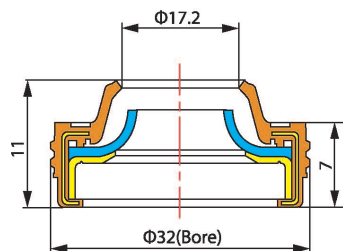

For 32C Bus, Nippon Denso
(日本电装) 10PA30C,
ZEXEL(杰克赛尔) DKS32C

技术参数:

压力: ≤0.3MPa
转速: ≤6000转/分
温度: -30°C ~ +150°C

- 金属件(A3铁/不锈钢)
- 橡胶件(氢化丁腈胶)
- 密封圈(聚四氟乙烯)

Operating Limits

Pressure: ≤0.3MPa
Rotary Speed: ≤6000r/min
Temperature: -30°C ~ +150°C

- Metal Parts(A3/SUS304)
- Rubber Parts(HNBR)
- Seal Ring(PTFE)

唇形包胶式轴封 Lip Shaft Seals with Rubber-mounted

TRISUN 冠

www.trisunltd.com
ISO9001 & TS16949

TS CB38x20

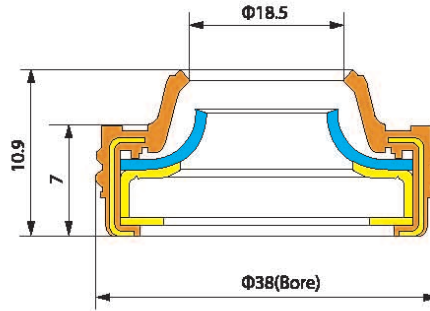

For Mitsubishi Unica(三菱)

TS CB59x40

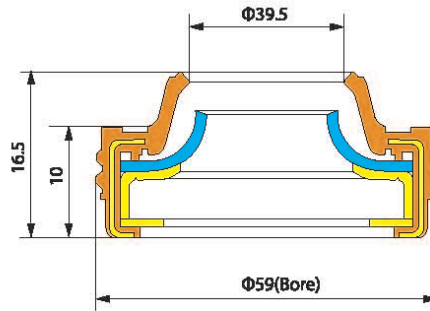

For Big Compressor(大巴)

TS CB-140S

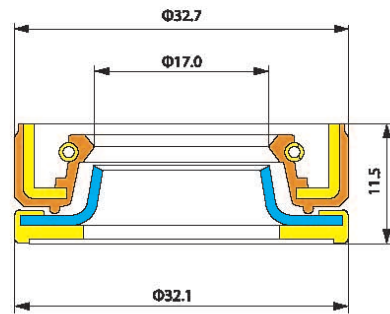

For Nissan NV140S SH-941 (尼桑)
Primar Selo Compressor CALSSONIC
NIHOW SELTEC, TM31 HD NVR140S
LIP SEAL (R134A)

技术参数:

压力: $\leq 0.3\text{MPa}$
转速: $\leq 6000\text{转/分}$
温度: $-30^{\circ}\text{C} \sim +150^{\circ}\text{C}$

- 金属件(A3铁/不锈钢)
- 橡胶件(氢化丁腈胶)
- 密封圈(聚四氟乙烯)

Operating Limits

Pressure: $\leq 0.3\text{MPa}$
Rotary Speed: $\leq 6000\text{r/min}$
Temperature: $-30^{\circ}\text{C} \sim +150^{\circ}\text{C}$

- Metal Parts(A3/SUS304)
- Rubber Parts(HNBR)
- Seal Ring(PTFE)

密封垫圈 Sealing Washers



For V5, R4, HD6, R12 / R134A

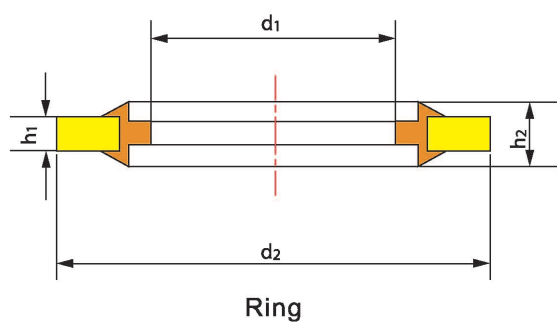

梅花式 Clups Type

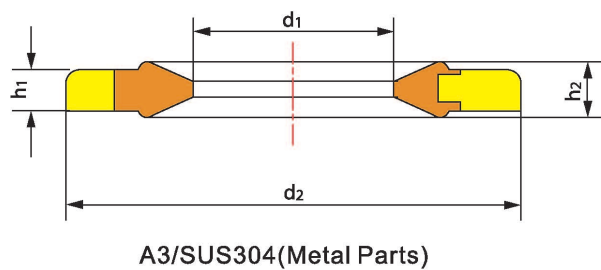

- 橡胶(丁腈胶/氢化丁腈胶) ● Rubber(NBR/HNBR)
- 骨架(A3铁) ● Frame Work(A3)

- 橡胶(丁腈胶/氢化丁腈胶) ● Rubber(NBR/HNBR)
- 骨架(A3铁) ● Frame Work(A3)

Model	d ₁	d ₂	h ₂	h ₁
TS0061	14.8	23.0	2.7	2.0
TS6a004-12	10.7	18.8	2.7	2.0
TS6a004-14	14.7	22.0	2.4	1.5
TS2a005-16	13.5	24.0	2.6	1.5
0139-10	8.7	14.0	1.8	1.0
0139-13	11.4	17.0	1.8	1.0
0139-17	15.0	22.0	2.1	1.3
0139-21	18.6	26.0	2.4	1.6
0139-27	24.0	32.0	2.4	1.6
0139-34	30.2	39.5	2.6	1.8

Model	d ₁	d ₂	h ₂	h ₁
GA-4500-KTC	15.0	29.5	4.0	3.0
GA-4502-KTC	15.2	28.0	2.0	1.4
GA-4503-KTC	17.5	31.0	2.0	1.5
GA-4505-KTC	16.8	31.5	2.0	1.4
GA-4506-KTC	15.5	30.0	7.5	5.3
GA-4507-KTC	15.5	30.0	4.8	3.8
GA-4508-KTC	15.0	33.5	4.2	3.0
GA-4509-KTC	15.4	23.7	1.9	1.3
GA-4510-KTC	8.4	16.0	2.0	1.4
GA-4511-KTC	11.2	19.2	2.2	1.4
GA-4512-KTC	17.4	25.4	2.2	1.4

空调压缩机用配件 Air Compressor Parts

TRISUN 天

www.trisunltd.com
ISO9001&TS16949

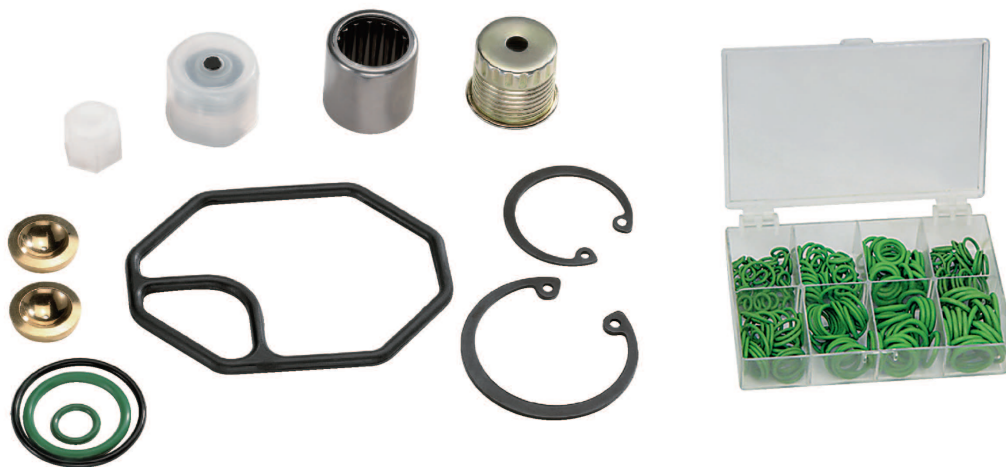

	Model	Dimension		Material
		D	d	
	O形圈 O Ring	1.0	1.5	丁腈胶/氢化丁腈胶 NBR/HNBR
		8.8	1.5	
		21.8	2.6	
		112.0	2.0	
		29.0	2.0	
		18.0	1.5	
	配套O形圈 YL-D004 O Ring Kit (240 PCS)	6.07	1.78	
		13.7	1.9	
		8.8	1.9	
		15.0	1.8	
		10.6	2.4	
		13.8	2.5	
		10.9	1.9	
		17.3	2.5	
	方形圈 Square Ring	116方形圈	116 Square Ring	
	塑料护帽 Plastic Cap	29进气护帽	29 Gas Sprue Cap	聚丙烯/丁腈胶 POLYPROPYLENE/NBR
		25.7 进气护帽	25.7 Exhaust Cap	
		14加注阀护帽	14 Pouring Valve Protective Cap	
	镀锌钢护帽 Galvanized Steel Cap	7/8" 进气护帽	7/8" Gas Sprue Cap	镀锌钢/丁腈胶 10F/NBR
		3/4" 进气护帽	3/4" Exhaust Cap	
	密封垫 Gaskets	For SD505/507/508		橡胶板 Rubber Sheet
	八角垫 Octagonal Washers	For Nippondenso 10PA15,10PA17,10PA20 Suction Discharge part		丁腈胶/氢化丁腈胶 NBR/HNBR
	挡圈 Retaining	Φ31.5, Φ40		锰钢 65Mn

电子控制阀系列 Electronic Control Valve Series

TRISUN 冠

www.trisunltd.com
ISO9001 & TS16949



TSECV01C

用于三电 PXE13 / PEX16 压缩机(带组装连接器)

车型: 奥迪, 西亚特, 大众, 波罗

长度: 10.1cm

Suitable for: SandenPXE13 / PEX16 compressor
(with assembly connector)

Application: Audi, Seat, Volkswagen, POLO

Product length: 10.1cm



TSECV02C

TSECV02O

TSE20-7014/TSE20-7007

用于电装 6SEU12C / 7SEU17 / 7SEU17C / 5SE12C /
7SEU16C / 6SEU14C / 6SEU16C 压缩机

C- S 车型: 奔驰

C- D 车型: 奥迪, 宝马, 斯柯达, 丰田

O-Purple 车型: 奔驰

O-Yellow 车型: 奔驰

O-Blue 车型: 宝马

长度: 9.3cm

Suitable for: Denso 6SEU12C / 7SEU17 / 7SEU17C / 5SE12C /
7SEU16C / 6SEU14C / 6SEU16C compressor

C- S Application: Benz

C- D Application: Audi, BMW, Skoda, Crown/Reiz

O-Purple Application: Benz

O-Yellow Application: Benz

O-Blue Application: BMW

Product length: 9.3cm

TSECV03C

TSECV03O

用于电装 7SEU16C / 6SEU12C / 7SEU17 压缩机(带组装
连接器)

C/O-BMW 车型: 宝马

C/O-POLO 车型: 奥迪, 斯柯达, 波罗

C/O-BENZ 车型: 奔驰

长度: 9.3cm

Suitable for: Denso 7SEU16C / 6SEU12C / 7SEU17
compressor (with assembly connector)

C/O-BMW Application: BMW

C/O-POLO Application: Audi, Skoda, POLO

C/O-BENZ Application: Benz

Product length: 9.3cm



电子控制阀系列 Electronic Control Valve Series

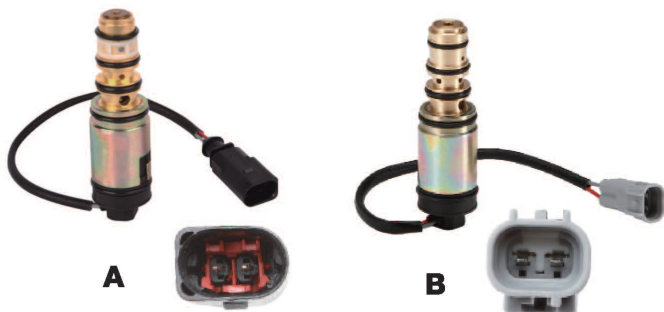

TSECV04C-A TSECV04C-B (New)

用于电装 6SEU16 压缩机(带组装连接器)
车型: 丰田
长度: 9.7cm
Suitable for: Denso 6SEU16 compressor
(with assembly connector)
Application: Toyota
Product length: 9.7cm



TSECV05C TSECV050 TSE20-7010/TSE20-7017

用于电装 5SE09C / 5SE12C / 6SEU16 / 7SEU16 压缩机
车型: 丰田凯美瑞
C 长度: 9.8cm
O- L 长度: 9.75cm
O- S 长度: 9.63cm
Suitable for: Denso 5SE09C / 5SE12C / 6SEU16 /
7SEU16 compressor
Application: Toyota Camry/Corolla
C Product length: 9.8cm
O- L Product length: 9.75cm
O- S Product length: 9.63cm



TSECV06C

用于三电PXE16/PXE13 压缩机
车型: 奥迪, 西亚特, 斯柯达, 大众
长度: 7.2cm
Suitable for: Sanden PXE16/PXE13 compressor
Application: Audi, Seat, Skoda, Volkswagen
Product length: 7.2cm



TSECV07C

用于三电 PXE16 / PXE13压缩机(带组装连接器)
车型: 奥迪, 西亚特, 法比亚, 波罗, 大众
长度: 7.2cm
Suitable for: Sanden PXE16 /PXE13compressor
(with assembly connector)
Application: Audi, Seat, Fabia, POLO, Volkswagen
Product length: 7.2cm

电子控制阀系列 Electronic Control Valve Series

TRISUN 冠

www.trisunltd.com
ISO9001&TS16949



TSECV08C

用于杰克赛尔DCS17E压缩机

车型: 奥迪, 西亚特, 大众

长度: 9.7cm

Suitable for: Zexel DCS17E compressor

Application: Audi, Seat, Volkswagen PQ35

Product length: 9.7cm



TSECV09C

TSECV090

用于三电 6C12/7C16 压缩机

车型: 雪铁龙、标致

长度: 9.4cm

Suitable for: Sanden 6C12/7C16 compressor

Application: Citroën, Peugeot

Product length: 9.4cm



TSECV10C

TSECV100

TSE20-7020

用于电装 6SEU12 / 6SEU16 / 7SEU16 压缩机

车型: 奥迪、大众

长度: 9.2cm

Suitable for: Denso 6SEU12 / 6SEU16 / 7SEU16 compressor

Application: Audi, Volkswagen

Product length: 9.2cm



TSECV11C

用于三电 PXE13/PXE16 压缩机

车型: 奥迪, 西亚特, 大众

长度: 10cm

Suitable for: Sanden PXE13/PXE16 compressor

Application: Audi, Seat, Volkswagen

Product length: 10cm



TSECV12C

用于康奈可CWE618压缩机

车型: 英菲尼迪

长度: 9.2cm

Suitable for: Calsonic CWE618 compressor

Application: Infiniti

Product length: 9.2cm

电子控制阀系列 Electronic Control Valve Series



TSECV13C TSECV130

用于康奈可CSE613压缩机
车型: 宝马
长度: 9.3cm
Suitable for: Calsonic CSE613 compressor
Application: BMW E90
Product length: 9.3cm



TSECV14C

用于三电7C16压缩机
车型: 雪铁龙、标致
长度: 10.2cm
Suitable for: Sanden 7C16 compressor
Application: Citroën, Peugeot
Product length: 10.2cm



TSECV15C TSECV150

用于电装 5SL12压缩机
车型: 菲亚特, 欧宝
长度: 7.2cm
Suitable for: Denso 5SL12 compressor
Application: Fiat, Opel
Product length: 9.2cm



TSECV16C

用于德尔福CVC压缩机
车型: 雷诺
长度: 8.9cm
Suitable for: Delphi CVC compressor
Application: Renault
Product length: 8.9cm



TSECV17C

用于电装 6SEU / 7SEU 压缩机
车型: 丰田
长度: 9.6cm
Suitable for: Denso 6SEU / 7SEU compressor
Application: Toyota
Product length: 9.6cm

电子控制阀系列 Electronic Control Valve Series

TRISUN 天

www.trisunltd.com
ISO9001&TS16949



TSECV18C

用于德尔福CVC压缩机
长度: 8.7cm

Suitable for: Delphi CVC compressor
Product length: 8.7cm



TSECV19C

TSECV190

用于德尔福6CVC14压缩机
车型: 大众, 奥迪, 斯柯达
长度: 8.7cm

Suitable for: Delphi 6CVC14 compressor
Application: Volkswagen, Audi, Skoda
Product length: 8.7cm



TSECV20C

TSECV200

用于三电PXE16压缩机
车型: 奥迪, 斯柯达, 大众
长度: 7.8cm

Suitable for: Sanden PXE16 compressor
Application: Audi, Skoda, Volkswagen
Product length: 7.8cm



TSECV21C

TSECV210

用于三电PXE16 / PXE14压缩机
车型: 通用, 菲亚特, 标致
长度: 8.8cm

Suitable for: Sanden PXE16 / PXE14 compressor
Application: GM EP2 / Delta, Fiat, Peugeot
Product length: 8.8cm



TSECV22C

TSECV220

TSE20-7011/TSE20-7013

用于电装5SE09C/5SE12C/6SEU16压缩机
车型: 奔驰, 雷克萨斯, 丰田
长度: 9.3cm

Suitable for: Denso 5SE09C / 5SE12C / 6SEU16 compressor
Application: Mercedes Benz, Lexus, Toyota Crown / Reiz
Product length: 9.3cm

电子控制阀系列 Electronic Control Valve Series



TSECV23C TSECV230

用于三电压缩机
车型: 宝马
长度: 8.5cm
Suitable for: Sanden compressor
Application: BMW
Product length: 8.5cm



TSECV24C TSECV240

用于德尔福CVC16 / CVC14 压缩机
车型: 通用
长度: 8.8cm
Suitable for: Delphi CVC16 / CVC14 compressor
Application: GM EP2 / Delta
Product length: 8.8cm



TSECV25C TSECV250

用于德尔福 CVC 压缩机
车型: 宝马
长度: 8.6cm
Suitable for: Delphi CVC compressor
Application: BMW
Product length: 8.6cm



TSECV26C TSECV260

用于电装 5SE09C/5SE12C/6SEU16 压缩机
车型: 奔驰, 宝马
长度: 9.5cm
Suitable for: Denso 5SE09C/5SE12C/6SEU16 compressor
Application: Mercedes Benz, BMW
Product length: 9.5cm



TSECV27C TSECV270

用于电装5SE09C / 5SE12C / 6SEU16 压缩机
车型: 丰田
长度: 9.9cm
Suitable for: Denso 5SE09C / 5SE12C / 6SEU16 compressor
Application: Toyota Camry / Highlander
Product length: 9.9cm

电子控制阀系列 Electronic Control Valve Series

TRISUN 天

www.trisunltd.com
ISO9001&TS16949



TSECV28C TSECV280

用于电装7SE / 6SE / 5SE压缩机
车型: 大众, 奥迪, 斯柯达
长度: 8.5cm
Suitable for: Denso 7SE / 6SE / 5SE compressor
Application: Volkswagen, Audi, Skoda
Product length: 8.5cm



TSECV29C TSECV290

用于电装压缩机
车型: 丰田, 别克
长度: 9.8cm
Suitable for: Denso compressor
Application: Toyota, Buick Park Avenue
Product length: 9.8cm



TSECV31C TSECV310

用于电装压缩机
车型: 雪铁龙, 标致
长度: 9.2cm
Suitable for: Denso compressor
Application: Citroën, Peugeot
Product length: 9.2cm



TSECV32C TSECV320

用于杰克赛尔DCS17压缩机(带组装连接器)
长度: 10.2cm
Suitable for: Zexel DCS17 compressor
(with assembly connector)
Product length: 10.2cm



TSECV33C TSECV330

用于电装5SE09C / 5SE12C / 6SEU16压缩机
车型: 丰田
长度: 9.6cm
Suitable for: Denso 5SE09C / 5SE12C / 6SEU16
compressor
Application: Toyota Yaris
Product length: 9.6cm

电子控制阀系列 Electronic Control Valve Series



TSECV34C **TSECV340**

用于电装7SE / 6SE压缩机
车型: 宝马
长度: 8.9cm
Suitable for: Denso 7SE / 6SE compressor
Application: BMW
Product length: 8.9cm



TSECV35C **TSECV350**

用于电装7SE / 6SE压缩机
车型: 奔驰, 宝马, 奥迪
长度: 8.7cm
Suitable for: Denso 7SE / 6SE compressor
Application: Mercedes Benz, BMW, Audi
Product length: 8.7cm



TSECV36C **TSECV360** *TSE20-7021*

用于电装6SEU16C压缩机
车型: 丰田
长度: 12.3cm
Suitable for: Denso 6SEU16C compressor
Application: Toyota Camry / Corolla
Product length: 12.3cm



TSECV37C **TSECV370** *TSE20-7022*

用于电装6SEU16C压缩机
车型: 丰田
长度: 11.9cm
Suitable for: Denso 6SEU16C compressor
Application: Toyota Crown / Reiz
Product length: 11.9cm

电子控制阀系列 Electronic Control Valve Series

TRISUN 冠

www.trisunltd.com
ISO9001& TS16949



TSECV38C

用于电装压缩机

车型: 丰田

长度: 9.86cm

Suitable for: Denso compressor

Application: Toyota Crown / Reiz

Product length: 9.86cm



TSECV39 O

用于电装压缩机

车型: 奔驰C200, 法雷奥

长度: 10.1cm

Suitable for: Denso compressor

Application: BENZ C200, Valeo

Product length: 10.1cm



TSECV410

用于电装压缩机

车型: 丰田雅力士

长度: 9.86cm

Suitable for: Denso compressor

Application: Toyota Yaris

Product length: 9.86cm

机械控制阀系列 Mechanical Control Valve Series



TSMCV01C-绿色/Green

用于V5压缩机 压力: 37.5psi
车型: 雪佛兰, 大宇, 通用, 哈里森
长度: 7cm

Suitable for: V5 compressor.

Pressure: 37.5psi

Application: Chevrolet, Daewoo, GM, Harrison

Product length: 7cm



TSMCV01C-黄色/Yellow

用于 德尔福CVC165 / CVC185 压缩机 压力: 40psi
车型: 雪佛兰, 大宇, 通用, 哈里森
长度: 7cm

Suitable for: Delphi CVC165 / CVC185 compressor

Pressure: 40psi

Application: Chevrolet, Daewoo, GM, Harrison

Product length: 7cm



TSMCV01C-紫色/Purple

用于V5压缩机 压力: 41psi
车型: 雪佛兰, 大宇, 通用, 哈里森
长度: 7cm

Suitable for: V5 compressor

Pressure: 41psi

Application: Chevrolet, Daewoo, GM, Harrison

Product length: 7cm



TSMCV01C-蓝色/Blue

用于V5压缩机 压力: 42psi
车型: 雪佛兰, 大宇, 通用, 哈里森
长度: 7cm

Suitable for: V5 compressor

Pressure: 42psi

Application: Chevrolet, Daewoo,
GM, Harrison

Product length: 7cm



TSMCV01C-棕色/Brown

用于V5压缩机 压力: 43psi
车型: 雪佛兰, 大宇, 通用, 哈里森
长度: 7cm

Suitable for: V5 compressor

Pressure: 43psi

Application: Chevrolet, Daewoo,
GM, Harrison

Product length: 7cm



TSMCV01C-红色/Red

用于V5 R12(老款)压缩机
压力: 44psi
车型: 雪佛兰, 大宇, 通用, 哈里森
长度: 7cm

Suitable for: V5 R12 (old type) compressor

Pressure: 44psi

Application: Chevrolet, Daewoo,
GM, Harrison

Product length: 7cm



TSMCV01C-橙色/Orange

用于V5 / V7 压缩机 压力: 45psi
车型: 雪佛兰, 大宇, 通用, 哈里森
长度: 7cm

Suitable for: V5 / V7 compressor

Pressure: 45psi

Application: Chevrolet, Daewoo,
GM, Harrison

Product length: 7cm

机械控制阀系列 Mechanical Control Valve Series

TRISUN 派

www.trisunltd.com
ISO9001&TS16949



TSMCV02C **TSMCV020** A20-5021

用于电装5SL12 / 5SA12 / 5SA09 / 6SBU16 / 7SBU16 压缩机
车型: 菲亚特, 奔驰, 欧宝, 路虎, 萨博, 斯柯达,
大众, 现代, 起亚
长度: 5.1cm
Suitable for: Denso 5SL12 / 5SA12 / 5SA09 / 6SBU16 /
7SBU16 compressor
Application: Fiat, Mercedes Benzi, Opeli, Land Rover, Saab,
Skoda, Volkswagen, Hyundai, KIA
Product length: 5.1cm



TSMCV03C-A (pressure: 0.186MPa) **TSMCV03C-B (pressure: 0.176MPa)** **TSMCV03C-C (pressure: 0.147MPa)**

用于三电 7V16 压缩机
车型: 菲亚特, 福特, 标致, 雷诺, 路虎, 西亚特, 斯柯达,
大众, 沃尔沃, 雪铁龙
长度: 4.8cm
Suitable for: Sanden 7V16 compressor
Application: Fiat, Ford, Peugeot, Renault, Land Rover, Seat,
Skoda, Volkswagen, VOLVO, Citroën
Product length: 4.8cm



TSMCV04C-A (pressure: 0.186MPa) **TSMCV04C-B (pressure: 0.176MPa)** **TSMCV04C-C (pressure: 0.147MPa)**

用于三电 7V16 / 6V12 / 7V12 压缩机
车型: 菲亚特, 福特, 标致, 雷诺, 路虎, 西亚特,
斯柯达, 大众, 沃尔沃, 雪铁龙
长度: 5.3cm
Suitable for: Sanden 7V16 / 6V12 / 7V12 compressor
Application: Fiat, Ford, Peugeot, Renault, Land Rover,
Seat, Skoda, Volkswagen, VOLVO, Citroën
Product length: 5.3cm



TSMCV06C

用于用于三电 TRV090 压缩机
车型: 福特, 捷豹, 马自达, 本田
长度: 3.4cm
Suitable for: Sanden TRV090 compressor
Application: Ford, Jaguar, Mazda, Honda Accord
Product length: 3.4cm

机械控制阀系列 Mechanical Control Valve Series



TSMCV07C-A

用于伟世通VS16压缩机
车型: 福特, 沃尔沃
长度: 5.5cm
Suitable for: Viston VS16 compressor
Application: Ford, VOLVO
Product length: 5.5cm



TSMCV07C-B

用于伟世通VS18压缩机/汉拿压缩机
车型: 福特, 现代
长度: 5.5cm
Suitable for: Viston VS16 compressor / HCC compressor
Application: Ford, Hyundai
Product length: 5.5cm



TSMCV08C

用于电装6C17 / 6CA17C / 7SB16C压缩机
车型: 斯柯达, 大众, 萨博, 路虎, 欧宝
长度: 5.8cm
Suitable for: Denso 6C17 / 6CA17C / 7SB16C compressor
Application: Skoda, Volkswagen, Saab, Land Rover, Opel
Product length: 5.8cm



TSMCV09C

用于康奈可CWW616 / CWW618压缩机
车型: 尼桑
长度: 6.9cm
Suitable for: Calsonic CWW616 / CWW618 compressor
Application: Nissan
Product length: 6.9cm

机械控制阀系列 Mechanical Control Valve Series

TRISUN 冠

www.trisunltd.com
ISO9001&TS16949



TSMCV10C

用于电装7SB16H / 7SB16 / 7SBU16H压缩机

车型: 雷克萨斯

长度: 6.3cm

Suitable for: Denso 7SB16H / 7SB16 / 7SBU16H compressor

Application: Lexus

Product length: 6.3cm



TSMCV11C

用于德尔福压缩机

长度: 5.1cm

Suitable for: Delphi compressor

Product length: 5.1cm



TSMCV12C

用于杰克赛尔DCW-17压缩机

车型: 奥迪

长度: 4.2cm

Suitable for: Zexel DCW- 17 compressor

Application: Audi

Product length: 4.2cm



TSMCV130

用于三电7V16压缩机

长度: 4.4cm

O- C 车型: 福特, 奇瑞, 长城

O- D 车型: 大众、宝来

O- F 车型: 大众、保罗

Suitable for: Sanden 7V16 compressor

O- C Application: Ford, MenDeo, Chery, Changcheng

O- D Application: Volkswagen Lavida, Bora

O- F Application: Volkswagen, Polo

Product length: 4.4cm

H型膨胀阀系列 H Type Expansion Valve Series



Q1HU-20001

Application: JEEP
Liquid In: 3/8"
Liquid Out: 1/2"
Suction In: 1/2"
Suction Out: 5/8"
Usrt: 0.5T-2.5T
OE: J-4205085



Q1HU-20002

Application:
Liquid In: 3/8"
Liquid Out: 1/2"
Suction In: 1/2"
Suction Out: 5/8"
Usrt: 0.5T-2.5T
OE: P-329-504



Q3HU-20003



Q3HU-20004

Application: BENZ
Liquid In: 3/8"
Liquid Out: 1/2"
Suction In: 5/8"
Suction Out: 3/4"
Usrt: 0.5T-2.5T
OE: M-1408300384



Q3HU-20005

Application: BENZ
Liquid In: 3/8"
Liquid Out: 1/2"
Suction In: 5/8"
Suction Out: 3/4"
Usrt: 0.5T-2.5T
OE: M-2018300784



Q4HU-20006

Application: GM
Liquid In: 6
Liquid Out: 8
Suction In: 10
Suction Out: 12
Usrt: 0.5T-2.5T
OE: G-52495729



Q3HU-20007

Application: NISSAN
Liquid In: 3/8"
Liquid Out: 1/2"
Suction In: 5/8"
Suction Out: 3/4"
Usrt: 0.5T-2.5T
OE: N-92200-4Y800/
AL500



Q3HU-20008

Application: HYUNDAI/KIA
Liquid In: 5/16"
Liquid Out: 5/8"
Suction In: 5/8"
Suction Out: 5/8"
Usrt: 0.5T-2.5T
OE: H-97626-3E000;
K-K0BJ161140



Q3HU-20009

Application: BMW
Liquid In: 1/2"
Liquid Out: 5/8"
Suction In: 3/4"
Suction Out: 3/4"
Usrt: 0.5T-2.5T
OE: B-64119182512



Q2HU-20010

Application: CHRYSLER
Liquid In: 3/8"
Liquid Out: 1/2"
Suction In: 3/4"
Suction Out: 3/4"
Usrt: 0.5T-2.5T
OE: C-4677203

H型膨胀阀系列 H Type Expansion Valve Series

TRISUN 天

www.trisunltd.com
ISO9001&TS16949



Q3HU-20011

Application: TOYOTA
Liquid In: 5/16"
Liquid Out: 5/8"
Suction In: 5/8"
Suction Out: 5/8"
Usrt: 0.5T-2.5T
OE: T-88515-33010



Q3HU-20012

NEW

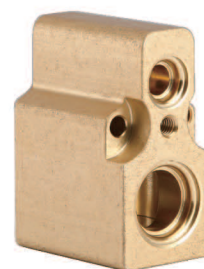

Q3HU-20013

Application: Volkswagen/SKODA/SEAT
Liquid In: 3/8"
Liquid Out: 1/2"
Suction In: 5/8"
Suction Out: 3/4"
Usrt: 0.5T-2.5T
OE: V-6N0820679C



Q2HU-20014

Application: DODGE
Liquid In: 3/8"
Liquid Out: 1/2"
Suction In: 3/4"
Suction Out: 3/4"
Usrt: 0.5T-2.5T
OE: D-4162473



Q3HU-20015

Application: CHRYSLER
Liquid In: 1/2"
Liquid Out: 5/8"
Suction In: 3/4"
Suction Out: 3/4"
Usrt: 0.5T-2.5T
OE: C-5019218AE



Q3HU-20016

Application: BENZ
Liquid In: 3/8"
Liquid Out: 1/2"
Suction In: 5/8"
Suction Out: 3/4"
Usrt: 0.5T-2.5T
OE: M-2108300484



Q3HU-20017

NEW



Q3HU-20018

Application: BENZ/SAAB
Liquid In: 3/8"
Liquid Out: 1/2"
Suction In: 5/8"
Suction Out: 3/4"
Usrt: 0.5T-2.5T
OE: M-2028300184-4319141



Q3HU-20019

Application: Volkswagen
Liquid In: 1/2"
Liquid Out: 5/8"
Suction In: 3/4"
Suction Out: 3/4"
Usrt: 0.5T-2.5T
OE: P-BC447600-2230



Q3HU-20020

Application: HONDA
Liquid In: 3/8"
Liquid Out: 5/8"
Suction In: 3/4"
Suction Out: 3/4"
Usrt: 0.5T-2.5T
OE: H-80220-S5A-G02

H型膨胀阀系列 H Type Expansion Valve Series



Q3HU-20021

Application: TOYOTA
Liquid In: 3/8"
Liquid Out: 5/8"
Suction In: 3/4"
Suction Out: 3/4"
Usrt: 0.5T-2.5T
OE: T-88515-02100



Q3HU-20022

Application: HYUNDAI
Liquid In: 5/16"
Liquid Out: 5/8"
Suction In: 5/8"
Suction Out: 5/8"
Usrt: 0.5T-2.5T
OE: H-97626-38000/F108-BBWAB-01



Q4HU-20023

Application: CHEVROLET
Liquid In: 6
Liquid Out: 8
Suction In: 10
Suction Out: 12
Usrt: 0.5T-2.5T
OE: C-10302742



Q3HU-20024

NEW

Application: TOYOTA
Liquid In: 3/8"
Liquid Out: 1/2"
Suction In: 5/8"
Suction Out: 3/4"
Usrt: 0.5T-2.5T
OE: T-88515-02100



Q3HU-20025

Application: BENZ
Liquid In: 3/8"
Liquid Out: 1/2"
Suction In: 5/8"
Suction Out: 3/4"
Usrt: 0.5T-2.5T
OE: M-2208300384



Q3HU-20026

Application: BMW E46
Liquid In: 3/8"
Liquid Out: 1/2"
Suction In: 5/8"
Suction Out: 3/4"
Usrt: 0.5T-2.5T
OE: B-64116904437



Q1HU-20027

Application: BENZ
Liquid In: 3/8"
Liquid Out: 1/2"
Suction In: 5/8"
Suction Out: 5/8"
Usrt: 0.5T-2.5T
OE: M-126-830-384



Q3HU-20028

Application: GM
Liquid In: 1/2"
Liquid Out: 1/2"
Suction In: 5/8"
Suction Out: 3/4"
Usrt: 0.5T-2.5T
OE: S-614915



Q3HU-20029

Application: TOYOTA
Liquid In: 3/8"
Liquid Out: 3/4"
Suction In: 3/4"
Suction Out: 3/4"
Usrt: 0.5T-2.5T
OE: D-447500-9050



Q3HU-20030

Application: TOYOTA
Liquid In: 3/8"
Liquid Out: 3/4"
Suction In: 3/4"
Suction Out: 3/4"
Usrt: 0.5T-2.5T
OE: T-88515-20100

F型膨胀阀系列 F Type Expansion Valve Series

TRISUN 拓

www.trisunltd.com
ISO9001&TS16949

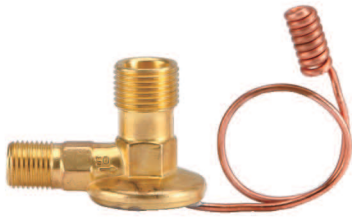

Q4FU-10001

Application: TOYOTA /MITSUBISHI
Inlet: 9/16"-18UNF
Outlet: 3/4"-16UNF
Fitting: O-ring
Usrt: 0.5T-2.5T
Part No: F-B15U4QEX
OE: T-88515-16040

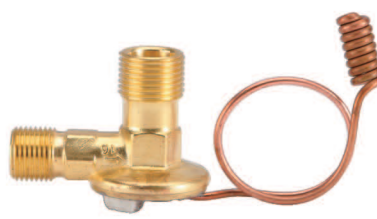

Q4FU-10002 **NEW**



Q4FU-10003

Application: TOYOTA
Inlet: 5/8"-18UNF
Outlet: 3/4"-16UNF
Fitting: Flare
Usrt: 0.5T-2.5T
Part No: F-A1534QEX
OE: T-88515-10010

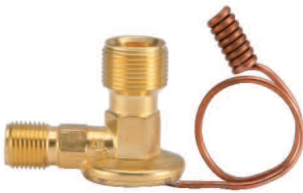

Q4FU-10004

Application: TOYOTA
Inlet: M16X1.5
Outlet: M22X1.5
Fitting: O-ring
Usrt: 0.5T-2.5T
Part No: F-B15K4QEX
OE: T-88515-34010

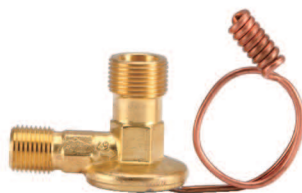

Q4FU-10005

Application: NISSAN/DAEWOO
Inlet: M16X1.5
Outlet: M20X1.5
Fitting: O-ring
Usrt: 0.5T-2.5T
Part No: F-B15KMQEX
OE: N-92200-59201T



Q4FU-10006

Application: HONDA
Inlet: M16X1.5
Outlet: M22X1.5
Fitting: O-ring
Usrt: 0.5T-2.5T
Part No: D-447500-1451
OE: H-80221-SOX-A51



Q3FU-10007

Application: NISSAN/ISUZU
/HYUNDAI
Inlet: M16X1.5
Outlet: M20X1.5
Fitting: O-ring
Usrt: 0.5T-2.5T
Part No: F-GBE-15KMQEX
OE: I-153-030-1950
/I-8-97229-628-0



Q2FU-10008

Application: GM/FORD/JEEP
Inlet: 5/8"-18UNF
Outlet: 3/4"-16UNF
Fitting: O-ring
Usrt: 0.5T-2.5T
Part No: E-826-007
OE: G-5910590



Q2FU-10009

Application: FORD
Inlet: :5/8"-18UNF/M14X1.5
Outlet: 3/4"-16UNF
Fitting: O-ring
Usrt: 0.5T-2.5T
Part No: F-E7G2-19839-A



Q3FU-10010

Application:
Inlet: 5/8"-18UNF
Outlet: 3/4"-16UNF
Fitting: O-ring
Usrt: 0.5T-2.5T
Part No: F-YF2H-19849-AA

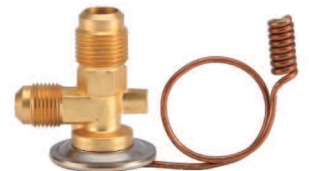

Q1FU-10011

Application: GM
Inlet: 5/8"-18UNF
Outlet: 3/4"-16UNF
Fitting: Frare
Usrt: 0.5T-2.5T
OE: E-826-012

W型膨胀阀系列 W Type Expansion Valve Series



Q3WU-30001

Application: MITSUBISHI
Inlet: 9/16"-18UNF(φ 8.45)
Outlet: 3/4"-16UNF(φ 13.1)
Equalizer: 7/16"-20UNF
Fitting: O-ring
Usrt: 0.5T-2.5T
Part No: F-GBE-E15U4QEX2
OE: M-MR168189

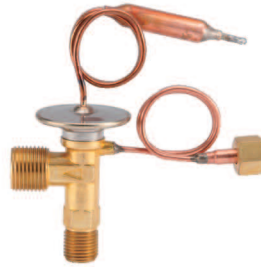

Q3WU-30002

Application: TOYOTA/HONDA
Inlet: 9/16"-18UNF(φ 7.45)
Outlet: 3/4"-16UNF(φ 11.9)
Equalizer: 7/16"-20UNF
Fitting: O-ring
Usrt: 0.5T-2.5T
Part No: F-GBE-E15U4QEX
OE: H-80220-ST7-A11



Q2WU-30003

NEW



Q2WU-30004

NEW



Q1WU-30005

NEW



Q2WU-30006

Application: MAZDA
Inlet: 3/8"-18UNF
Outlet: 3/4"-16UNF
Equalizer: 7/16"-20UNF
Fitting: O-ring
Usrt: 0.5T-2.5T
OE: M-60-0336-70



Q3WU-30007

Application: TOYOTA
Inlet: M16X1.5
Outlet: M22X1.5
Equalizer: M12X1.25
Fitting: O-ring
Usrt: 0.5T-2.5T
Part No: D-ND0460
OE: T-88515-22160



Q3WU-30008

Application: Volkswagen
Inlet: 5/8"-18UNF
Outlet: 3/4"-16UNF
Equalizer: 7/16"-20UNF
Fitting: Frare
Usrt: 0.5T-2.5T
OE: V-843-800-679A



Q3WU-30009

Application: NISSAN
Inlet: M16X1.5
Outlet: M20X1.5
Equalizer: M12X1.25
Fitting: O-ring
Usrt: 0.5T-2.5T
Part No: F-E15FFKT-3
OE: N-92200-F5001/60A00

控制阀测试设备 Control Valve Test Equipment

TRISUN 冠

www.trisunltd.com
ISO9001&TS16949



CONTROL UNIT

机械控制阀测试仪(T95-8008) 美国原装
Mechanical Control Valve tester (T95-8008)
made in U. S. A

电子测试仪(德国原装)
Electronic-type tester T95-1400(made in Germany)
全套电子控制阀测试仪包括: (T95-8008)+(T95-1400)
Full Set Electronic Control Valve tester includes: (T95-8008)+(T95-1400)

适用于: TSMCV01
Suitable for: TSMCV02
TSMCV03
TSMCV04
TSMCV06
TSMCV07
TSMCV08
TSMCV09
TSMCV10
TSMCV11
TSMCV12
TSMCV13

适用于: TSECV01 TSECV20
Suitable for: TSECV02 TSECV21
TSECV03 TSECV22
TSECV04 TSECV23
TSECV05 TSECV24
TSECV06 TSECV25
TSECV07 TSECV26
TSECV08 TSECV27
TSECV09 TSECV28
TSECV10 TSECV29
TSECV11 TSECV31
TSECV12 TSECV32
TSECV13 TSECV33
TSECV14 TSECV34
TSECV15 TSECV35
TSECV16 TSECV36
TSECV18 TSECV37
TSECV19 TSECV38

控制阀检测夹具 Control Valve Test Fixture



TSMCV02
T95-8011
7SBU/5SL



TSMCV08
T95-8025
7SB/6CA



TSMCV09
T95-8036
CWV618 / V6



TSECV01
TSECV11
TSECV14
T95-8031
PXE13/PXE16



TSECV02
TSECV03
T95-8029
6SEU12C/
6SEU16C



TSECV05
TSECV22
T95-8034
5SE09C/ 5SE12C



TSECV06
TSECV07
T95-8032
PXE13/PXE16



TSECV08
T95-8033
DCS17E



TSECV12
T95-8035
CWE618

压缩机唇封包装形式 Packing Type of LiP Seal



客户定制
Design as customer's requirements

1, 插卡包装 Slide Packing



2, 牛皮纸吸塑 Kraft-paper Blister Packing



3, 彩纸吸塑 Colorful-card Blister Packing

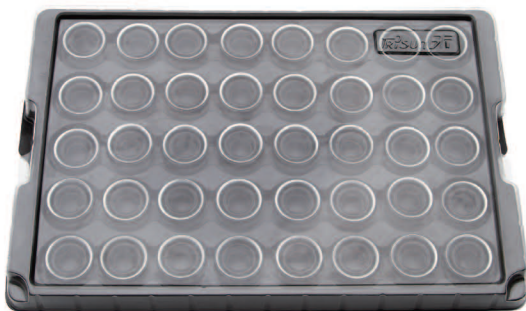

4, 黑色塑料托盘 Black Plastic Tray



5, 客户定制(吸塑配彩盒)

Design as customer's requirement (Blister with Colorful Box)

T95-8121 压缩机测试设备 Automobile Compressor Test Equipment

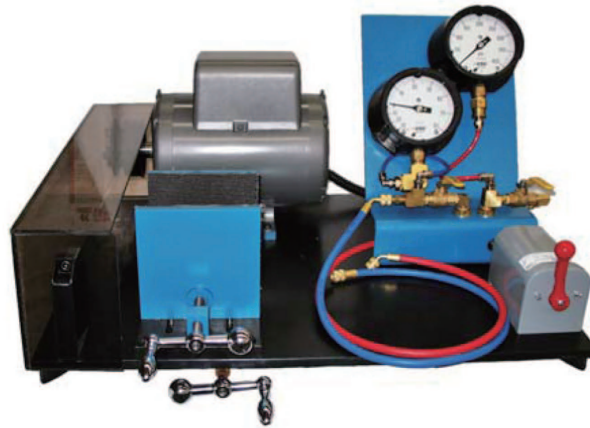

产地: 美国

体积: 1 X 0.6 X 0.6 米

重量: 120 公斤

MADE IN U.S.A

Volume: 1 X 0.6 x 0.6 meter

Weight : 120 kgs

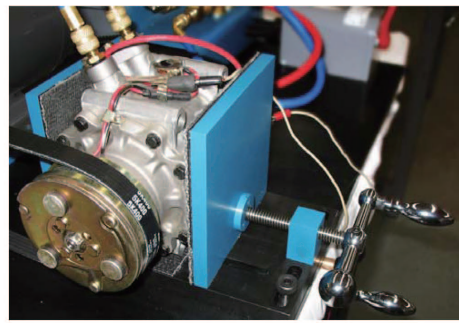
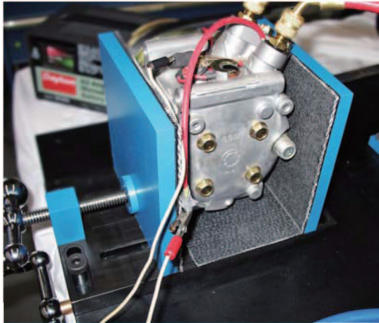

T95-8121是一款全功能动态测试仪。能够检测所有定排量和90%的变排量压缩机。（有些变排量压缩机不能在低压力感应时启动）。装上离合器测试，使用通用压缩机夹具。最多可容纳7英寸宽压缩机（TM-31）

功能：

1. 测试压缩机内外部的泄露
2. 测试簧片的吸排性能
3. 测试压缩机的运行性能

质保和安全措施：

1. 设有总操作安全焦点。（符合OSHA，ANSI标准）
2. 配有防爆仪表。
3. 在350 PSI 或24bar压力下,高压溢流阀预设
4. 所有配件均按重型工业级元件配置

The T95-8121 is a economical full function test machine suitable to all fixed displacement and 90% variable compressors. (Some variable compressors cannot be started with low side pressure induction).

Test with clutch mounted, using universal compressor fixture.Holds up to 7 inch wide compressors (TM-31)

Application :

1. External and internal leakage test
2. Suction and discharge reed test
3. Full function test

Safety Guarantee :

1. Total Operator Safety Focus. (OSHA, ANSI)
2. Explosion Proof Gauges.
3. High Pressure Relief preset at 350PSI 24 bar.
4. All Heavy Duty Industrial Grade Components

控制阀包装形式 Packing Type of Control Valve

彩盒包装 Color Box Packing



托盘包装 Tray Packing



纸盒包装 White Packing

